



OV320

MINI RACK OVEN

Space saving design with all the capabilities of the full-size model.



Proven technology. Authentic results.





OV320 Mini Rack Oven

Even baking, rack after rack

The OV320 mini rack oven by Baxter Manufacturing is a space-saving solution with the power of a full-size rack oven. Designed for efficiency, it incorporates a new Smart Touch™ control for precise temperature and steam management, ensuring even and consistent results. The user-friendly interface enhances ease of use, making it suitable for various baking and cooking applications. With its compact footprint, the OV320 delivers performance, reliability, and convenience in a versatile package.



- 1. Theatre Viewing:**
See what's cooking with a larger viewing window.
- 2. Storage:**
Stainless steel 12 pan storage for extra sheet pans.
- 3. Oven Stand:**
Heavy duty locking casters provide easy movement and stability.
- 4. Smart Touch Control:**
Intuitive, easy to use Smart Touch™ programmable digital touchscreen control: Self Diagnostics with Error Codes, 12 months of data collection, store a maximum of 99 recipes with up to 6 steps or stages. WiFi compatible.
- 5. USB Port and Gas Shut-Off Feature:**
Upload and download recipes in a snap. Also includes a gas shut-off feature (gas models only).
- 6. Loading Door:**
Large viewing window for theater effect. Interior glass of the doors fixed for rigidity while exterior glass swings open for easy cleaning between panes.
- 7. Removable Rotating Oven Rack:**
Ensures even cooking and baking, top to bottom and left to right without having to turn the pans. Removable rack for ease of cleaning interior cavity.
- 8. Increased Steaming Capabilities:**
Increases steam capacity by 33%, while a tight door seal ensures oven maintains steam levels throughout the cooking or baking cycle.
- 9. Integrated Hood:**
Integrated hood to evacuate heat, smoke and steam from door opening. Standard trim option available.
- 10. Improved Airflow:**
For better cooking or baking results.



OV320 Hood Option

OV320 Flat Trim Option

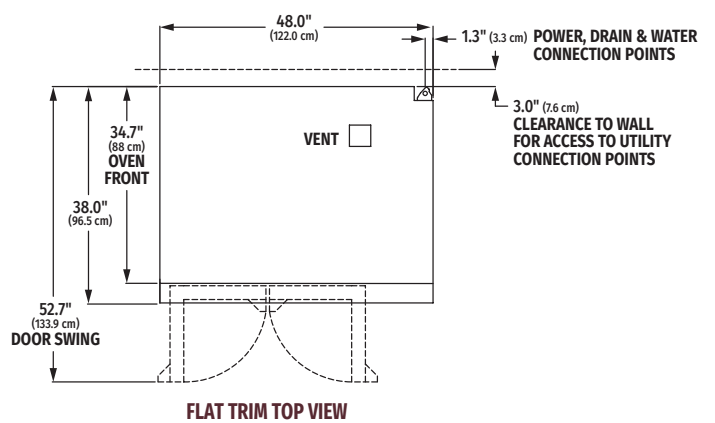
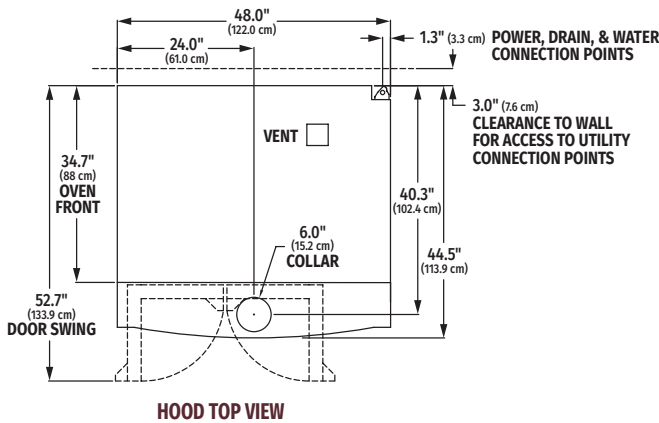
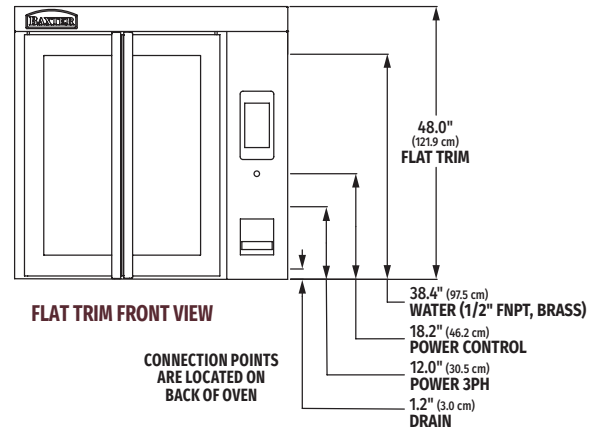
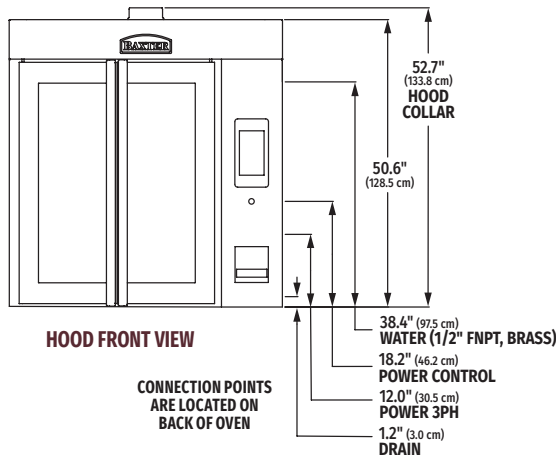

CAPACITY (Based on an 8 pan rack)

18" x 26" sheet pans	18" x 13" sheet pans	12" x 7" x 2.5" hotel pans
8	16	26

CONNECTION POINTS

Natural or Propane Gas	Power	Water	Drain	Venting	Burner System
3/4" MNPT 95,000 BTU/Hr Standard: Natural Gas @ 5" to 14" w.c. Optional: Propane Gas @ 11" to 14" w.c.	120V/60Hz/1Ph, 15 amp maximum dedicate circuit. 8' cord and NEMA 5-15 plug supplied	1/2" NPT, cold water	1/2" MNPT route to air-gap	8" diameter connection. Draft of 50 CFM required. Exhaust hood may be required. Consult local codes.	95,000 BTU/hr. in-shot burner system



For other Baxter products, check us out at www.baxtermfg.com or contact us at 1-888-350-7090

Proven technology. Authentic results.

BX56147 (05/24) ©Baxter